



This is a dual-purpose document that is designed to be the reference manual for the installation of the [Newton Control Panel-Pro](#) and then should be handed over to the occupier as the user manual and service record.

Panel Serial Number	
Date Installed	
Installation Company	
Installation Engineer	
Service Contact Number	

WARNINGS

SHOCK HAZARD – DO NOT OPEN.

THIS CONTROL PANEL MUST ONLY BE INSTALLED BY TRAINED ENGINEERS.

NO USER SERVICE PARTS INSIDE PANEL - DO NOT OPEN.

THIS PANEL HAS TWO 230 VAC MAINS POWER INPUTS AND A 12 VDC INPUT.

ALL THREE MUST BE ISOLATED BEFORE SERVICE OF PANEL OR PUMPS.



This Operational Manual is for use with Version 2 Control Panel-Pro only.

Please keep this Operational Manual with the Control Panel at all times. The service engineer should confirm findings using the service sheet below.

Date	Engineer	Readings Pump 1 Volts / Amp / Count / Hours	Readings Pump 1 Volts / Amp / Count / Hours

	PAGE
INFORMATION	2
SERVICE SHEET	2
INTRODUCTION	4
DESCRIPTION OF FEATURES	5-6
SET-UP OPTIONS	7
CONNECTING POWER, PUMPS & OPTIONAL EQUIPMENT	8-11
SIZING OF NEWTON VICTRON BATTERY BACKUP SYSTEMS	12
CONNECTION OF NEWTON DIALER TO CONTROL PANEL	13
ENGINEER OPTIONS	14
USER INSTRUCTIONS	15
SYSTEM AND PANEL MAINTENANCE	16
PANEL TEST CERTIFICATE	17
PANEL INTERNAL WIRING DIAGRAM	18-19

WARRANTY STATEMENT

Limited Product Warranties

One year limited product warranty from date on delivery note or invoice to the customer. Delivery note must include the product code number and serial number of the product.

What is covered by this limited hardware warranty?

This limited product warranty covers defects in materials and workmanship. This limited warranty covers warranty back-to-base (Newton Waterproofing Systems) only for defects in materials and workmanship. The manufacturer will exchange the product with a product that is new or which has been manufactured from new or serviceable used parts and is at least functionally equivalent to the original product.

What is not covered by this limited hardware warranty?

This limited product warranty does not cover:

- Products the supplier has not received payment for
- Normal wear and tear
- Problems with electrical power supply
- Failure to follow product installation instructions and user instructions
- Failure to perform preventive maintenance on the supplied product or the system the product is used within
- Usage that is not in accordance with the product instructions
- Servicing not authorised by the manufacturer
- Problems caused by connecting devices not supplied or authorised by the manufacturer

Warranty Information

This warranty gives you specific legal rights, and you may also have other rights which may vary from area to area (or jurisdiction to jurisdiction). The manufacturer's responsibility for malfunctions and defects in the product is limited to repair and replacement as set forth in this warranty statement. All expressed and implied warranties for the product, including but not limited to any implied warranties and conditions of merchantability and fitness for a particular purpose, are limited in time to the term of the limited warranty which is the one-year period reflected on your delivery note or invoice. No warranties, whether expressed or implied, will apply after the limited warranty period has expired.

We do not accept liability beyond the remedies provided for in this limited product warranty or for consequential or incidental damages, including without limitation, any liability for third-party claims against you, for damages for products not being available for use. Our liability will be no more than the amount you paid for the product that is the subject of a claim. This is the maximum amount for which we are responsible. Newton Waterproofing Systems reserve the right to change the product specification at any time.

The Newton Control Panel-Pro is a class-leading pump control panel with many unique features which has been designed by Newton Waterproofing Systems to provide the ultimate in pump operation and diagnosis. The panel includes interfaces for use with [Newton Victron Battery Backup](#) and Telemetry Systems, as well as connections to whole house alarm and monitoring systems. The Control Panel PCB is split into two separate circuits, ensuring that pumping will continue even if one of the control circuits should fail. This effectively means that the Newton Control Panel-Pro is two control panels within one case, offering unrivalled redundancy.

Self-diagnostic programs test the pumps on a weekly basis to ensure correct pump performance. The appointed service engineer is automatically informed of any detected problem with either of the pumps if the [Newton Dialer](#) telemetry system is either connected (Newton Purchase Code PA5) or installed within the panel (Newton Purchase Code CP7). A typical system is shown below:

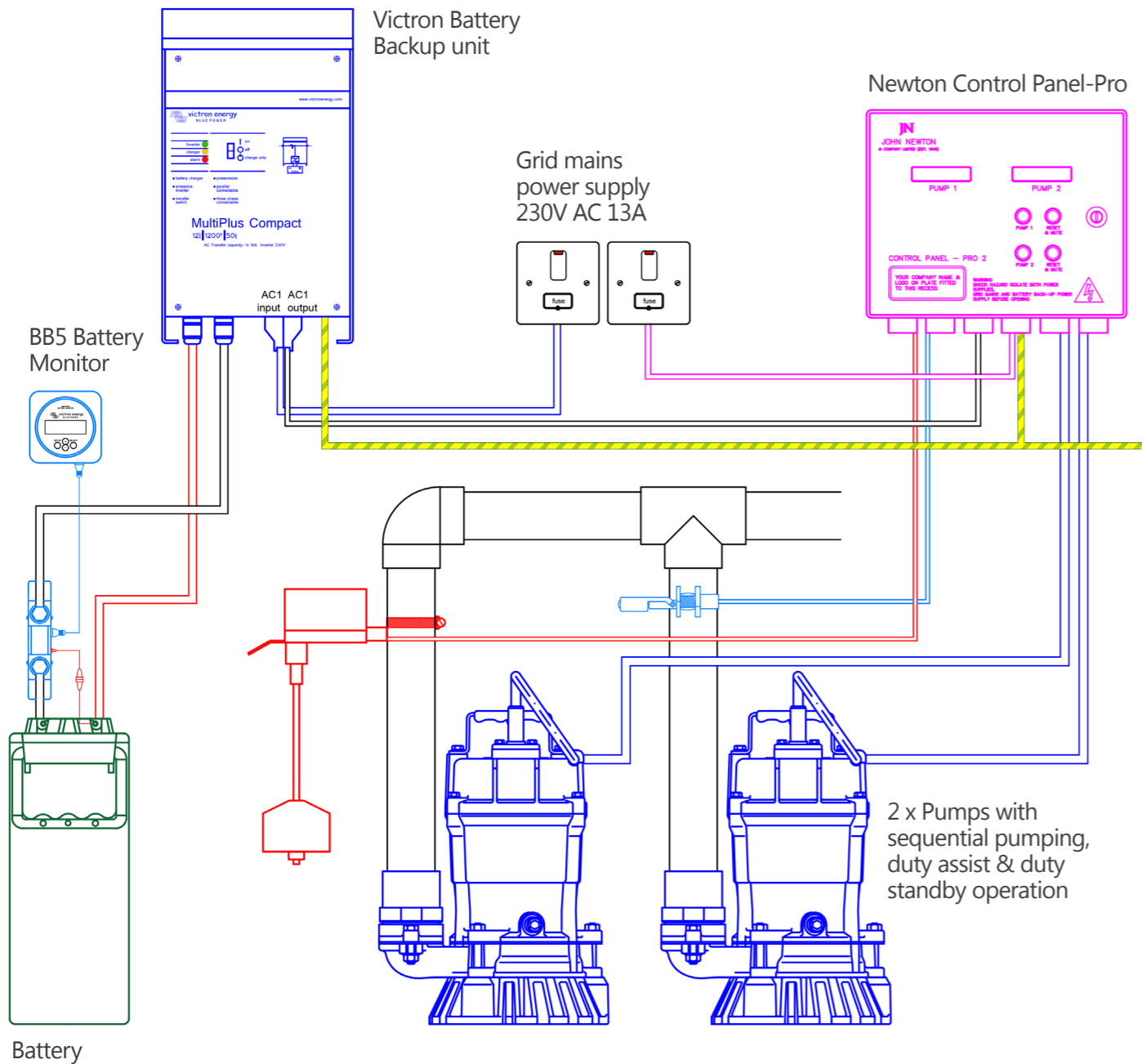

The Newton Control Panel-Pro will operate a maximum of two 750 W 230V AC pumps. The panel is supplied with a vertical water level float switch and [High Water Level Alarm](#) float switch. The panel is designed to be used with optional Newton Victron Battery Backup Systems, sized to suit the pumps and installed with sufficient battery power to ensure continued pumping during power outages.

PANEL HIGHLIGHTS

1. **Automatic alternate duty cycle** - Each time the main float switch calls for a pump to start, the panel will alternate the command to each pump to share the pump wear.
2. **Two independent power supply inputs** - One for grid mains and the other for a battery-backed power supply via an approved Newton Victron Battery Backup System. In the event of a grid mains failure, the panel automatically switches to battery power. On power restoration, the panel will automatically switch back to normal grid power mode and recharge the battery or batteries.
3. **Alarm on power failure** - Panel will alarm on mains failure. The mains fail beep will not sound in mains fail until a pump operation has occurred, or, if the pumps are not used, the sounder will beep after 12 hours. This is to prevent unnecessary alarms, mainly at night. An alarm output is sent to trigger the Newton voice and text Dialer (included with purchase code CP7) or home alarm at the time of the mains power failure.
4. **Automatic pump duty assist** - If one pump cannot cope with the volume of water entering the sump, the second pump will automatically start in order to increase the pumping capability. The time period before the second pump starts is adjustable (master timer setting) to accommodate different sized sumps. There is also the option to prevent both pumps running at the same time if the system is running from backup battery.
5. **Automatic current monitoring for each pump** - The panel checks that the pump is using the correct current when the pump has been switched on. If the current is too low or a pump cable has been disconnected, the panel will automatically switch to the second pump. The current in Amps is displayed for running pumps. As well as the panel audible alarm, an alarm output is sent to trigger the voice or text Dialer (where fitted or included) or home alarm/monitoring system at the time of a pump failure. There is approximately a 30 second delay before the sounder operates after a pump fault is detected. This is to allow the panel to check there is indeed a pump fault and to silence the sounder unless the fault is confirmed.
6. **Automatic main float checking** - If the main float fails or becomes disconnected, the alarm float automatically takes over as the main level control float (preset to 10 seconds). If in main float fail mode, the panel will still alternate both pumps via the alarm float. An alarm output is sent to trigger the voice or text Dialer in the event of main float failure.
7. **Automatic alarm float checking** - An alarm checking signal is continually monitored to confirm that the alarm float cables have been fitted correctly, not been tampered with, or been disconnected.
8. **Each pump has its own, totally separate electronic circuit** - This allows for one pump to still operate if a fault develops in the pump that could damage the panel electronics. An alarm output is sent to trigger the voice or text Dialer in the event of a controller failure.
9. **Automatic testing of each pump every 7 days** - Testing ensures the pumps are used each week and will report any problems detected during the 3 second test with an alarm. Each control circuit has its own independent timer to ensure that each pump is tested at different times.
10. **Each pump is controlled by a zero voltage solid state triac** - The triac device is controlled by very fast switching electronics that can detect the change to the 50 Hz cycle to initiate switching at zero voltage. Unlike mechanical relays or contactors, there are no moving parts to wear out or generate arcing dust or welding of contacts. This gives the control panel a life duty in the millions of pumping operations, unlike a mechanical relay that can be as low as 100,000 cycles.
11. **The panel monitors the power supply and will alarm if the incoming grid mains voltage fails** - The panel will give a loud beep once per minute in grid mains fail mode. The panel will also auto reset on power return.

12. **The panel monitors the power supply and will alarm if the current to each pump is too high or too low** - The panel automatically checks that the correct power is being used by each pump. If the pump is disconnected or a pump fuse has blown, the panel will sound a loud two beeps per minute. The alarm will also sound if the pump is using too much power. Must be reset by pressing the reset buttons or performing a full reset of the panel.
13. **Alarm sounder options** - Dip-switches on the sounder allow for programming of up to 32 different alarm sounds with a fully adjustable volume control also included.
14. **Engineer option to mute all sounds other than high water alarm** - This can be set by the engineer after a full panel reset. Hold down the pump 1 mute/reset button and then press the pump 1 button, then repeat this twice for each pump. The display will flash up AUX SOUNDER OFF. This will stop any beeping other than for a high water level if the customer requires it.
15. **Each pump circuit has it's own LCD display with a built in flash memory** - This display will:
 - A) Display and store the pump cycles and hours run in an independent flash memory chip for each pump
 - B) Display any alarms with the description of the alarm, water level high, pump fault, high current, mains failure and sounder off
 - C) Display the pump that is running, the current of the pump and the backup battery voltage, allowing the engineer to monitor pump efficiency and battery condition
 - D) Display the voltage of the converter battery in both grid mains and converter in use modes
 - E) Display if the panel has had the alarm sounder muted by user
 - F) Possess an engineer memory reset for resetting all timers and counters
 - G) Possess a 'service due' setting to inform the user that a service is due on the system (this function can be selected by the engineer)
16. **All float switches are 12 VDC (low voltage)** - Via two separate isolation transformers.
17. **Each pump has a manual override button and a reset button** - The pump button can be pressed at any time to operate the pump and the reset button to reset the display after an alarm (will not reset if pumping).
18. **Display memory resetting**
19. **Sounder mute** - If the sounder is beeping to warn of mains fail or pump fault, you can mute the sounder by pressing each mute/reset button twice. To remind the user of a muted fault, the mute function will cancel after 12 hours.
20. **Engineer reset of counters and timers** (engineer only - see page 15).

The Newton Control Panel - Pro is designed to be used with all or a selection of the following Newton pumping options:

- A choice of Newton manual pumps of 400 W and 750 W
- A range of Newton Victron Battery Backup Power Inverters to give continuation of pumping via the panel during power outage
- Newton Dialer, pre-fitted to code CP7, that will alert up to 8 different landline or mobile phones with either text or voice confirmation of the sounding of the alarm
- Newton PA50 High Water Level Alarm as a remote alarm in another location (requires twin core cable connection)
- Whole house management system (supplied by others). Home automation relays are mounted on the PCB to allow panel warnings to operate other systems. The relays are contacts volt free. The relays operate for 5 seconds on pump fault, water high or mains fail. Note that a mains fail is NC whilst the others are NO

As mentioned earlier, the panel has two control circuits; Pump 1 and Pump 2. Each circuit has a set of control dip switches and a timer. The position of these is shown in the diagram below.

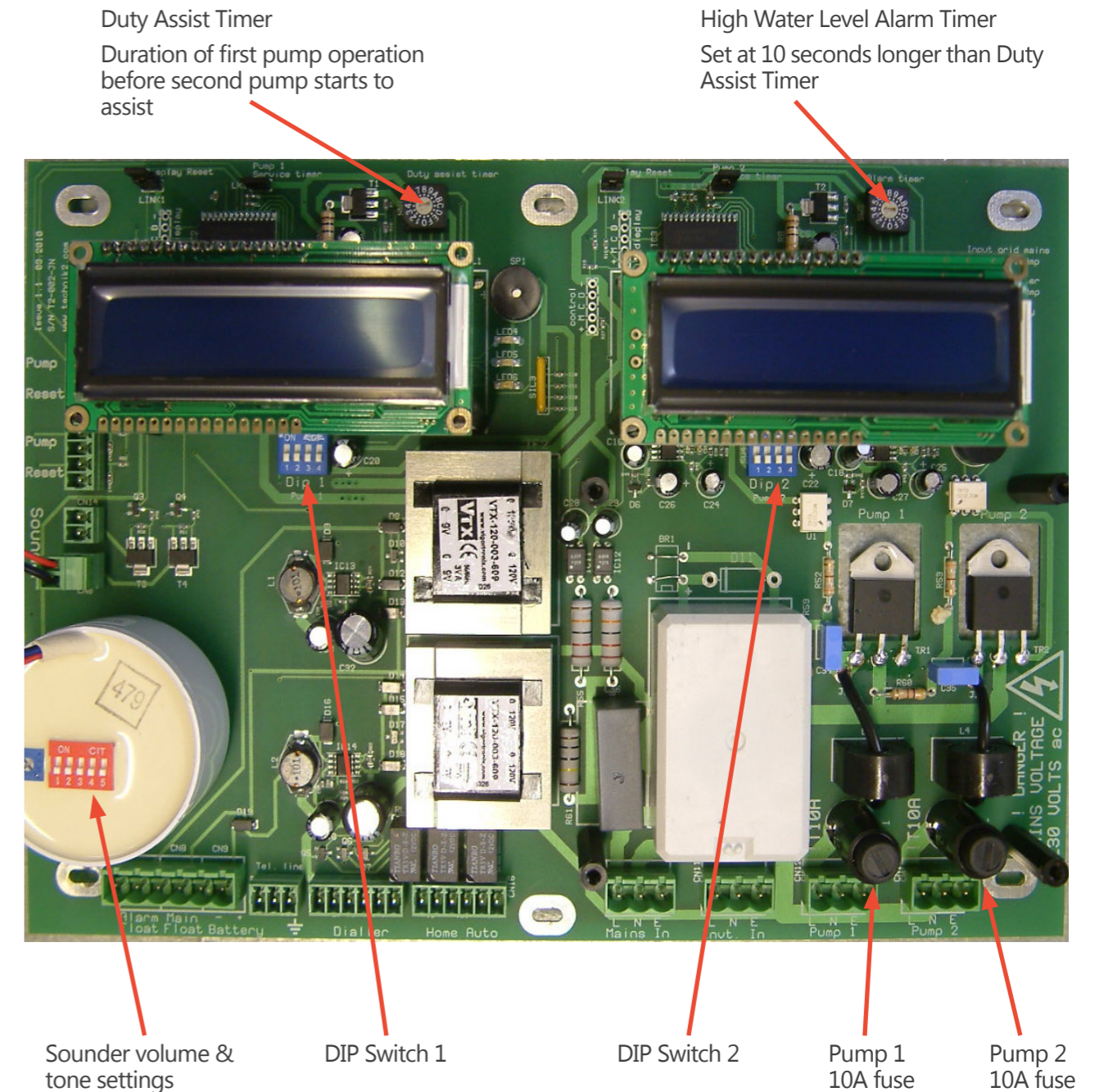

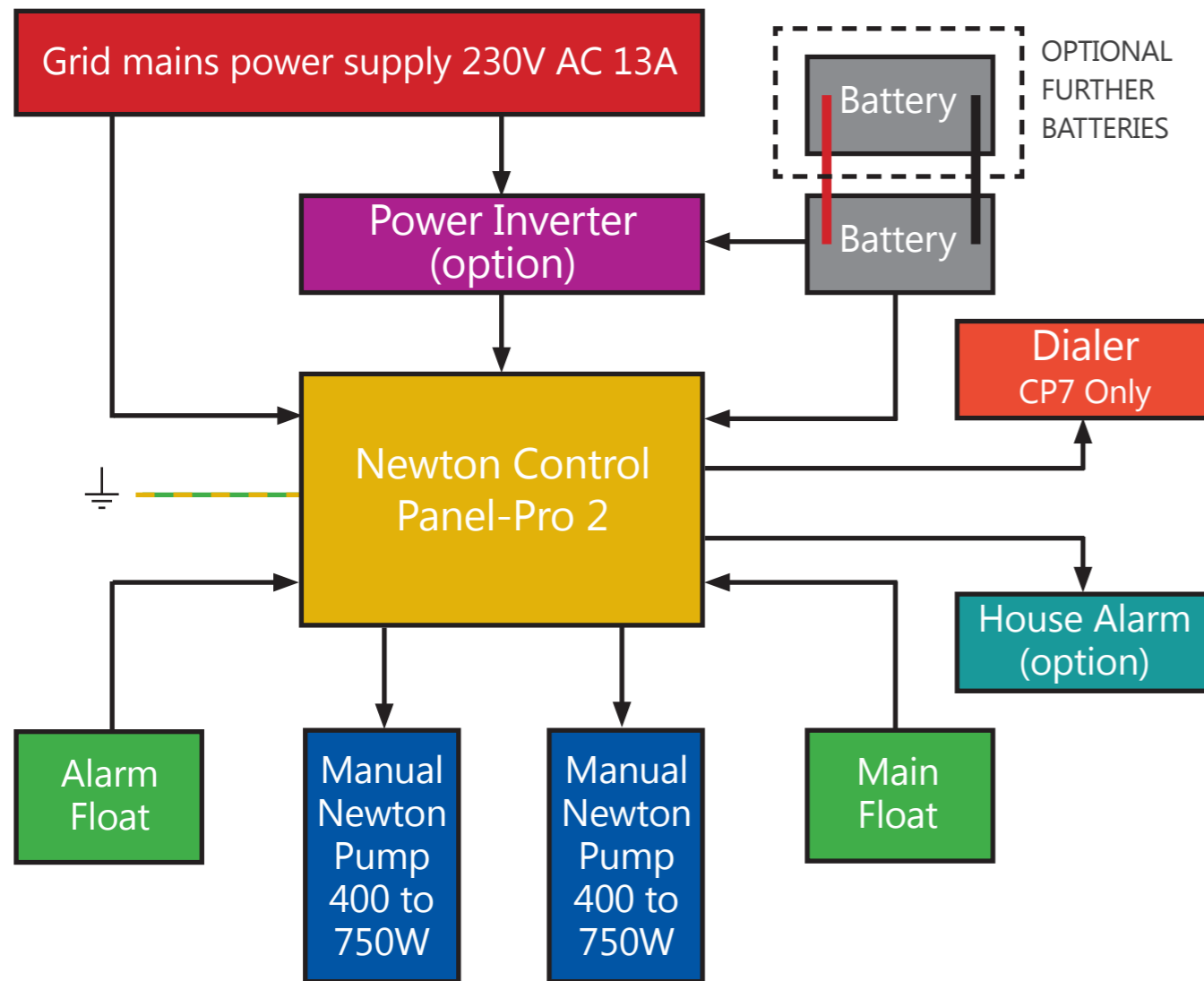

USER SELECTABLE DIP SWITCHES AND TIMERS

The Control Panel-Pro is supplied with the pump duty assist timers (shown on page 7) set to 30 seconds for Pump 1 and 40 seconds for Pump 2. This is the optimum setting for the [Newton NP400](#) pump within a [Titan-Pro](#) sump chamber. The installer should test the system to ensure that one pump completes a pumping cycle within this set time, before the second pump turns on to assist. Adjust the timers to suit. Always set the Pump 2 timer to be 10 seconds more than the Pump 1 timer.

The DIP switches are all set to OFF by default. With this setting the Duty assist function will only take place when the system has mains power. If the system is operating off 12 VDC battery power, the duty assist function is disabled so that the battery is not drained too quickly. If the system is powered by more than one battery with a combined storage of over 380 Ah, DIP 2 can be changed to ON, allowing for duty assist during power outages. If a single battery is used, we strongly advise not to use duty assist and that the DIP switches are all set to the OFF position. Please see page 12 for further information.

ELECTRICAL CONNECTION

INSTALLATION WARNINGS:

THIS CONTROL PANEL MUST ONLY BE INSTALLED BY TRAINED ENGINEERS.

BEFORE COMMENCING INSTALLATION, ISOLATE YOUR MAINS ELECTRIC SUPPLY.

This product should be installed in accordance with the relevant sections of the building regulations code and the current edition of the IEE Wiring Regulations (BS 7671: Requirements for electrical installations) and appropriate statutory regulations.

As of April 2004, new installations in the UK should be wired using the EU harmonised colours for the supply conductors. **NEW COLOURS: BROWN = Live, BLUE = Neutral, YELLOW / GREEN = Earth**

This installation **MUST** be earthed.

This control panel is not waterproof, is of a metal construction, and must be installed in a dry, well-ventilated area.

Warning: It is important to read and understand the control panel instructions

This Newton twin pump control panel has been designed to be wall-mounted or recessed within the wall. When the unit is recessed into the wall, the routing of all cables is also within the wall, making a neater installation than if the unit is wall-mounted. Cable entry is via the 7 cable glands on the bottom of the panel. An extension wiring kit for extending the distance from the panel to the pumps up to 50 M is available. The purchase code is PA-31 and is a special order with a two week delivery from order.

For ease of maintenance in changing pumps, it is recommended to only have one mains cable per 20 mm gland. Use the glands as indicated below (numbered from left to right):

1. Mains input cable
2. Power converter input cable
3. Pump one cable
4. Pump two cable
5. Main float cable
6. Alarm float cable.

Notes:

Low-voltage rated cables should not be run in the same conduit as mains (230V AC) cables. The panel must be earthed, not just earthed via a mains cable with a plug fitted! Use the earthing point mounted inside on the bottom of the housing by the gland entry points.

If the sump chamber is full of water on first powering up the panel, the alarm may sound and both pumps may start in sequence in pump duty assist mode. When the water level is below the main float top position, reset the panel by turning off the power supply for 5 seconds. On power up, the system will operate normally.

The display units can be reset after installation. Please see the instructions on page 15.

CONNECTION WIRING DIAGRAM

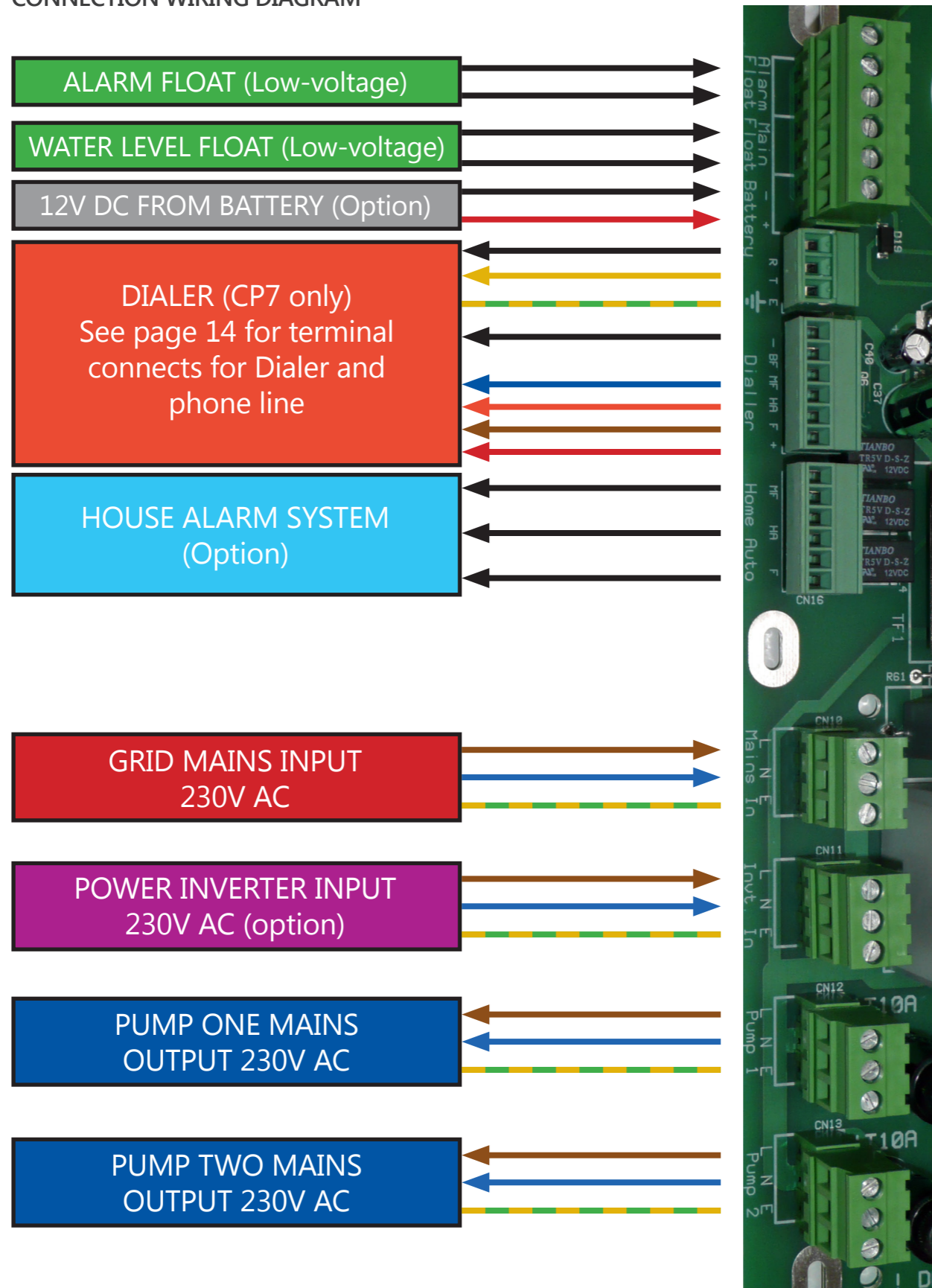

CONNECTION NOTES

- Connection of the grid mains electric supply should be carried out by a competent person
- Ensure that the grid mains connection is not connected until all connections are complete and the Control Panel casing is fitted and locked closed
- The Control Panel-Pro is supplied with terminal connectors. These are fitted into the motherboard terminals as shown on page 10. The terminal connectors allow for quick connection and disconnection to the board. Wiring can be connected to the terminal connectors whilst they are fitted to the board or away from the motherboard
- The Alarm Float is the smaller Reed Pivot Switch and the Level Switch is the larger Vertical Action Float Switch. The Alarm Float should be installed so that the switch is always closed and only opens when lifted upwards by rising water
- Both the Level and Alarm floats have two wires. The connection of these wires is not dependent on polarity and can be fitted to either of the terminals for each connection
- The Level Switch should be connected to the vertical discharge pipe of one of the pumps at a height that allows for the pumps to operate correctly. If the switch is too high, the switch may not operate until the water level in the sump is too high. If the switch is too low, it is possible that the pump removes all the water before the switch has turned off. It is vitally important to test the pump switching to ensure the pumps operate correctly
- The Alarm Float should be fitted to the vertical discharge pipe of one of the pumps at a height that is above the Level Switch

As an approximate guide, with 400 W pumps, one can expect to pump about 12,000 litres of water with a full NorthStar NSB 190FT battery. This figure is based upon a system with a new battery and the pumps operating to approximately a 4 m head with approximately 15 minutes between pumping cycles, allowing for battery recovery time in between each operation. Further information can be found on page 3 of the Newton Victron Inverters Data Sheet.

The default set-up of this control panel has the 'pump duty assist' disabled when the mains power fails, to prevent very high current draw from the battery if running two pumps together. This setting protects the backup battery from sudden discharge and will allow the system to pump more water for much longer with the limited power supply available in the battery. The default DIP setting is OFF on all four DIPs on both the Pump 1 and Pump 2 DIP switches.

If pump duty assist is required during a power failure, we recommend that a minimum battery capacity of 380 Ah is used. This is achieved by connecting multiple batteries in parallel (4x 100 Ah or 2 x 191 Ah). To change the default setting, change DIP 2 on both DIP Switches to ON. **Note:** Battery performance is dictated by many factors such as the storage temperature and age of the battery, the rising main diameter, overall length, head and the number of bends, tees and elbows.

POWER CONVERTER SIZING				
PUMP SIZE	DUTY ASSIST	DIP 2 SETTING	CONVERTER	SIZE OF BATTERIES
400W	NO	OFF	MultiPlus 12/1200/50	100 Ah or more
400W	YES	ON	MultiPlus 12/3000/120	380 Ah or more
750W	NO	OFF	MultiPlus 12/3000/120	190 Ah or more
750W	YES	ON	MultiPlus 12/3000/120	760 Ah or more

Only use Newton Victron Power Inverters coupled with approved and correctly sized NorthStar Batteries with this control panel. Newton Victron Power Inverters have been designed to work with Newton Pumps and have special software for battery charging and inverter cooling. All Newton Victron Power Inverters are tested and calibrated to very high standards before being dispatched from the factory and meet all UK safety requirements.

Newton Victron Power Inverters include powerful charging circuits and special cooling fan control software. Newton Power Inverters have a three-stage charging circuit: Bulk - For when the battery is very depleted; Absorption - For a final top-up charge and Float - A trickle-charge that replaces lost charge. The Inverters are silent except when in Bulk Mode.

INSTALLATION OF POWER INVERTERS

Power Inverters must be stored in dry conditions before installation. Power Inverters must be installed in a dry cool area, with good air circulation and NOT directly above the battery or sealed in an airtight box. Do not install the Power Inverter near the head of a bed or opposite a wall where someone sleeps. All installations that have grid mains and generated mains power must be correctly labelled, to inform the user that both power supplies must be isolated before maintenance. Power Inverters can cause electrocution; take great care to isolate mains and battery before working on systems by unplugging them. **Follow the instructions included with the Inverter for battery sizing and installation.**

Although only 12V, batteries have very high currents of 300 Amps plus, so if you short the terminals with a spanner, ring or watch for example, they would become white hot in less than 1 second. For this reason you must remove all metallic rings, watches or any object that may cause a short. If the battery is an open vent type, you must wear safety glasses and PPE to prevent acid burns. The Power Converter must not have the mains power connected when fitting the battery cables. Joints must be dry and clean. It is very important that the connection is good and secure, as a bad joint will heat up and cause the cable insulation to melt (fire risk), the voltage to vary, and the Power Converter electronics will be damaged. The battery terminals MUST be covered by a tamper-proof method and not exposed.

WIRING DIAGRAM

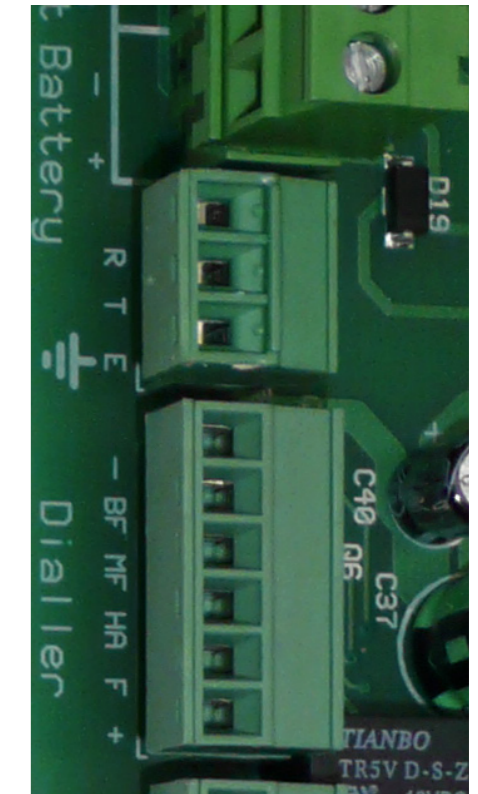
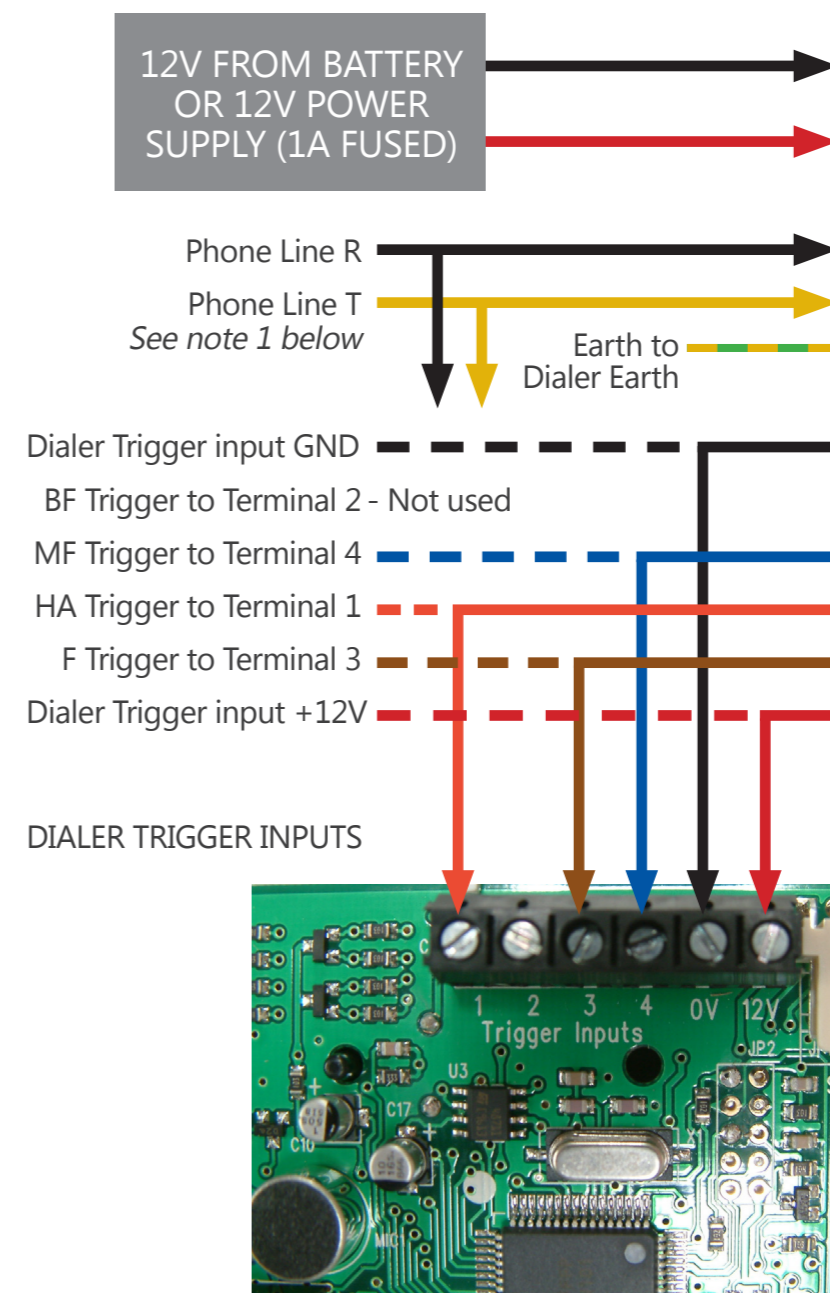

PROGRAMMED INPUTS

1. Water Level High
2. Not used
3. Pump Requires Attention
4. Pump Mains Failure

All warnings followed by "press button 8 to acknowledge"

WARNING - Outputs from the Control Panel to the Newton Dialer are +5V triggers. DO NOT SHORT TERMINALS TO +12V TO TEST, AS THIS WILL DAMAGE THE CONTROL PANEL PCB.

Note 1: Connection of the phone line to the panel is only required when the Dialer is fitted within the panel housing. The panel terminals receive the T & R wires from the phone line and further T & R wires connect from the terminals to the Dialer, effectively using the panel terminals as a junction box. If the Dialer is fitted externally to the panel, only the Earth is required from the Dialer to the panel.

SERVICE DUE SETTING

The engineer can select the service due function by adding a jumper to both service timer contacts. This will time down from 365 days to "service due" (will not time days when the panel is not powered up). To reset the service timer, add jumper links to both service timer and display reset links. Press and hold down the reset buttons until the display reads memory reset. You have to do this for each pump display. If service due setting is NOT required do not place the jumpers on the two "service timer" links. See below for position of service timer & display reset jumper links.

RESETTING COUNTER MEMORY AND SERVICE TIMES

To reset the counter and hour meters, link the display reset jumper and remove the service timer link. Press the reset button until the display reads memory reset. After resetting, replace the service timer link & remove the display reset link.

Pump 1 Jumper Settings

Pump 2 Jumper Settings

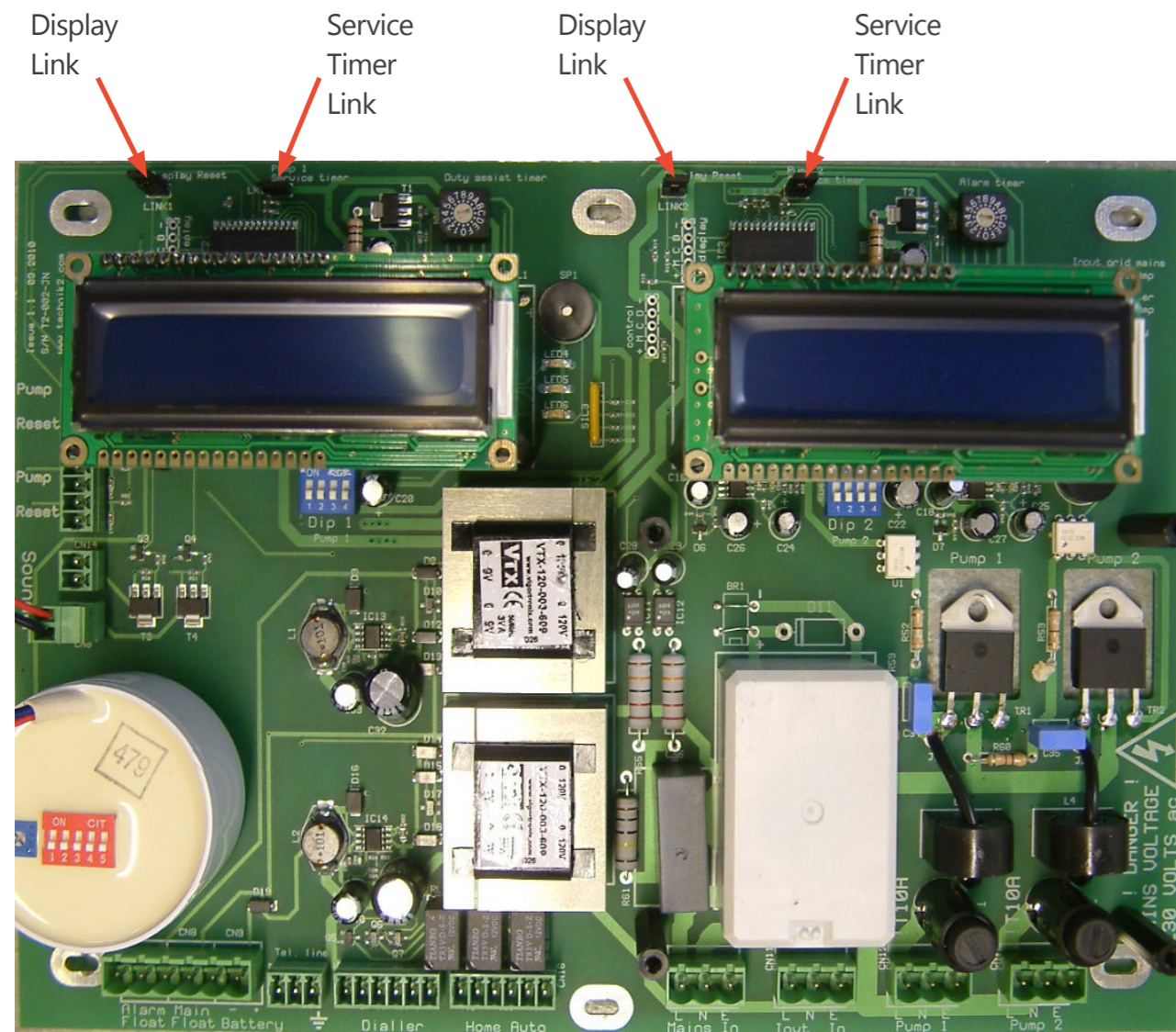

DISPLAY INFORMATION

1. PUMP CYCLES & PUMP HOURS RUN - (Default display) Displays the cycles and running hours for each pump from date of installation or engineer reset
2. HIGH CURRENT - Warning of a pump pulling more current than normal. This information may be displayed when both pumps are running or in mains failure mode. CALL ENGINEER only if this information is displayed in normal use for longer than 24 hours
3. WATER HIGH ALARM - This warning happens when:
 - A. The water level reaches the small alarm float or the wires to the alarm float have been cut
 - B. The main float has failed or the wires to the main float have been cut
 - C. Both pumps have failed and no water is being pumped from the sump chamber
- DANGER OF FLOODING - CALL ENGINEER. Check power is on to the Panel, check cables and float switches, check any fuses. Requires both reset buttons to be pressed to reset the warning
4. MAINS FAILURE - Grid mains to the Panel is off and it is running on emergency power from the Power Converter and battery. The alarm will beep once per minute after a pump cycle during mains failure. Depending on the amount of water flow, battery age and condition, the running time from one battery can vary from minutes to days. Auto-reset on power restoration
5. PUMP FAULT - This indicates that one of the pumps is either not connected, damaged, pumping air, or an internal pump protection fuse has blown (10 A) due to a major pump fail. The alarm will BEEP twice per minute, 30 seconds after the pump failure. CALL ENGINEER. Press both reset buttons to reset
6. PUMP CURRENT, BATTERY VOLTS - This information is only displayed when a pump is running. The information is for the engineer to monitor the current that each pump is using and the condition of the backup battery voltage. This information is also useful in mains fail mode to check the back up battery voltage when a pump is running. The voltage in normal use on grid mains should be 13.5 -14.8 Volts, this indicates the back up battery is being charged
7. SOUNDER OFF - This information warns the user the alarm sounder has been MUTED. If the alarm sounder is active and cannot be reset, CALL ENGINEER
8. DISPLAY BACK-LIGHT - The back-light will be on low when the panel is powered up. The back-light will go bright to indicate which pump is running, the display will show the pump current and battery voltage
9. SERVICE DUE - This information indicates the service option has been activated by the engineer and the annual pump service is now due. CALL ENGINEER

Note, warning information or alarm sounders can be reset by pressing the reset buttons (it will not reset if pressed while the display back-light is bright or the pumps are running). The reset will only happen if the reason of the warning has been corrected. If it cannot be reset, CALL ENGINEER.

To MUTE the sounders: Each display has its own internal warning sounder and the panel has one main alarm sounder. ONLY MUTE THE SOUNDERS IF YOU ARE SURE. CALL ENGINEER IF THE PANEL INDICATES A FAULT OR SOUNDS AN ALARM YOU CANNOT RESET.

To mute an alarm: Press the mute buttons twice on each pump when the pumps are not running. This will mute the sounder for 12 hours only. To remind the user of a muted fault, the mute function will cancel after 12 hours. YOU CAN ONLY MUTE THE SOUNDER WHEN THE PUMP(S) ARE NOT RUNNING.

TO CANCEL MUTE (sounder off), turn both grid mains and inverter mains off for approximately 5 seconds. This will reset the mute function.

OPERATING A PUMP MANUALLY . To operate each pump manually, press the pump button. The display back-light will brighten and the display will show pump current in amps and the backup battery voltage. Both pumps can be operated if the panel is operating on mains power. If the panel is powered via the Power Converter and battery, the panel (with default settings) will allow one pump to operate at a time.

EVERY MONTH

1. Test the water high float each month by lifting the float switch in the sump chamber. The sounder will sound and one of the pumps will start for 10 seconds. When the pump has stopped, press both reset buttons for approximately 5 seconds each (if a Dialer is connected answer the call and press button 8 on the phone to acknowledge alarm)
2. Press each pump button for approximately 5 seconds in turn to check each pump is working (the panel does an automatic check each week for a 3 second test on each pump)
3. Check the panel displays for any warnings, if any, note and press both of the reset buttons for approximately 5 seconds and check display again after the next pumping cycle. If the warning has not cleared, contact your service company

EVERY 6 MONTHS

1. The panel does not contain any serviceable items. Wipe the outside of the panel case with a clean, dry cloth

EVERY 12 MONTHS

1. The system will require servicing by a qualified service engineer to check:
 - A. The condition of the pumps for wear or loss of efficiency
 - B. The service/pump timers
 - C. The amount of water pumped by the system since the last service
 - D. The condition of the sump and any deposits in the bottom of the chamber
 - E. The condition of the Basedrain drainage channels, pipework and water outlet pipes
 - F. The backup battery condition (voltage and capacity under load)
 - G. The condition of the large cables from the battery to the converter and the battery connections
 - H. The condition of the Power Inverter, if fitted (test backup system by turning off the mains to both the Panel and Power Converter)
 - I. Test the Dialer if installed
 - J. Reset service timers and counters if required

RECORD THE SERVICE USING THE SHEET ON PAGE 2.



PANEL TEST CERTIFICATE

Panel Serial Number Test Date

Part Number

TEST

1. Power up panel and test each pump completes its first 3 second burst test
2. Check both pump buttons work
3. Check both pumps alternate with water at high flow (minimum of 10 cycles)
4. Check water high alarm float works (disconnect main float)
5. Check if pumps alternate in alarm condition and pump for 10 seconds each
6. Check displays for correct current, battery volts, cycles and back light
7. Check if both pumps work together in high water flow rates on mains power
8. Check that only one pump works on backup power only from converter
9. Check dialer, display and sounder for water high alarm
10. Check dialer, display and sounder for mains fail
11. Check dialer, display and sounder for pump fault
12. Check sounder mute functions
13. Check pumps run for a minimum of 20 full cycles in normal mode
14. Check and reset displays to zero (check jumper links are in place)

Notes:

This twin pump control panel has been tested to the above tests. All tests are completed on a test rig pumping water from a sump chamber to an outlet 4 metres high from chamber water level, using 750W pumps.

Signed Name In Capitals

© Newton Waterproofing Systems
(a trading name of John Newton & Co. Ltd.)

Newton House, 17-20 Sovereign Way, Tonbridge, Kent, TN9 1RH

T: +44 (0)1732 360 095 W: www.newtonwaterproofing.co.uk E: info@newtonwaterproofing.co.uk

PANEL INTERNAL WIRING DIAGRAM

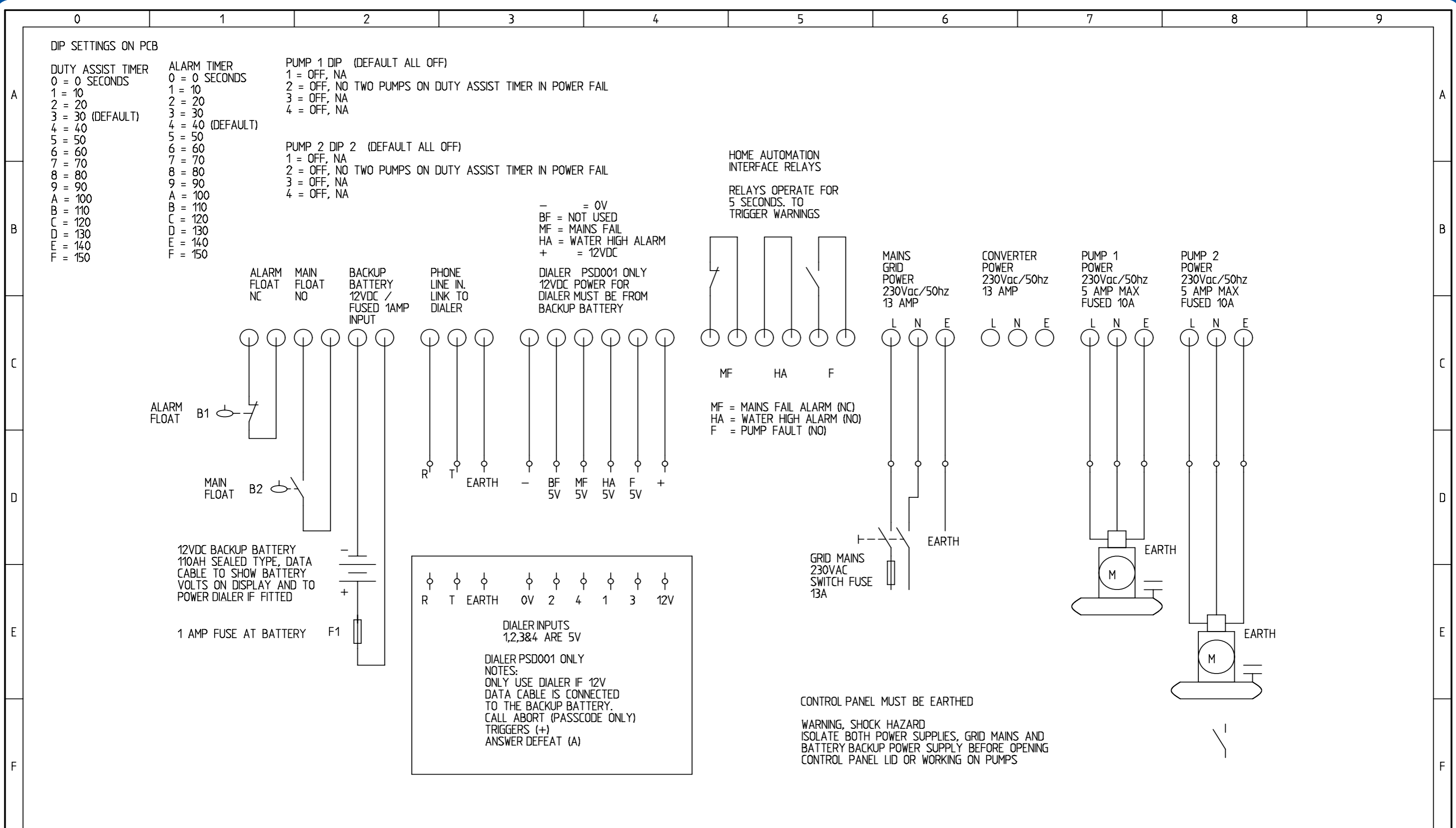

CP-PRO-2	CONTROL PANEL PRO-2 CONNECTION DRAWING TO EN61346-2UK	Twin pump PRO-2 Issue 2 with converter DIAGRAM WITHOUT NEWTON POWER CONVERTER	Project: 08.11.2010	Drawing no.:	Init.: GWW	Rev.:	Sheet: 1
			Date: 08/11/2010	Function: =	Location: +	Total sheets: 1	Next sheet:

JN[®]

NEWTON

WATERPROOFING

Newton Waterproofing Systems Is A Trading Name Of

John Newton & Company Ltd.

Newton House, 17-20 Sovereign Way
Tonbridge, Kent TN9 1RH

T: +44 (0)1732 360095

E: info@newtonwaterproofing.co.uk

W: www.newtonwaterproofing.co.uk

